

**Harmar**

Installation and Owner's Manual

# **HIGHLANDER**

## **Commercial Platform Lift**



**CPL400**  
**CPL600**  
**CPL800**  
**CPL1000**  
**CPL1200**  
**CPL1400**  
**CPLP400**  
**TG400**

 **Read manual thoroughly before attempting to install or operate lift.**

This manual has been provided to assist you with lift installation and operation. For further assistance please contact your authorized Harmar dealer or Harmar's Technical Service department.

Tel: 866-378-6648  
Fax: 816-537-0641

Dealer:

Serial Number:

## **Table of Contents**

### **Installing the lift**

Using the Manual_____	2
When You Receive the Lift_____	3
Specifications_____	3
Safety_____	3
Code Requirements_____	4
Site Requirements_____	4
Required Tools_____	4
Required Materials_____	4
Preparing to Install the Lift_____	5
Controller Harness Connections_____	5
Installing the platform_____	6
Installing the outer guard panel_____	7
Installing the fixed ramp_____	7
Installing the folding ramp_____	8
Anchoring the Lift_____	9
Setting the Limit Switches_____	10
Verifying Operation of the Lift_____	11
Manual Override_____	12
Call-Sends (optional)_____	12
Top Landing Gate (optional)_____	13
EMI and Flush Strike (optional)_____	14
Platform Gate (optional)_____	15
Fascia Panel (optional)_____	16
Alarm (optional)_____	17
Owner's Section_____	18
Safety_____	19
Controls_____	20
Operating the Lift_____	21
Warranty_____	30

### **Using the Manual**

This manual will provide step by step instructions on how to install and operate your lift. Read and understand the entire manual before beginning to install the lift.

**If you have any questions, contact Harmar technical service at 1-866-378-6648**

## When You Receive the Lift

- Check the lift for shipping damage. If you see any damage contact the freight carrier to file a damage claim.
- Verify the products match that described on the packing list attached to the exterior packaging.
- Verify the contents of the package match that shown below to the right.

## Specifications

Payload Capacity	750 lbs
Vertical Travel	54" – 171"
Height	77" – 197"
Foot Print	VARIABLES
Platform Size	36" x 54" / 36" x 60" / 42" x 60"
Input Voltage	115vac - 20a
Control Voltage	24vac or 24vdc
Platform Speed	10 ft/min
Motor	1/2hp-90vdc or 1/2hp-24vdc



## Safety

- Read all instructions in this manual before installing or operating the lift.
- Do not exceed the maximum payload capacity of 750 lbs.
- Do not ride on the lift until it is anchored in place.
- This product is designed only for lifting people and wheel chairs. Do not use it for any other purpose.
- Always wear eye protection while installing or servicing this product.
- Always disconnect this product from the electrical source before servicing it.
- Only use the fasteners supplied with this lift.
- Do not wear loose clothing or jewelry when working on this product.
- Do not disable any safety equipment or switches supplied with this lift.
- Stay away from all drive train components while the lift is operating.

## **Code Requirements**

Your lift has been designed to meet ASME A18.1 section 2 and CSA B44/ASME A17.5, with the addition of certain options. Code requirements for Vertical Platform lifts vary depending on location. It is the installers responsibility to contact their local code enforcement office and determine all of the regulations they are subject to. You must do this before installing the Vertical Platform Lift.

## **Site Requirements**

- The lift will require a 115vac 20amp grounded circuit.
- Outdoor Installations will require a GFI protected circuit.
- Only install the lift on a 4" thick , level 3,500 psi reinforced concrete slab.
- Foot Print varies depending on platform size and options.

## **Required tools**

- 1/2" Hammer Drill
- 3/8" Masonry Drill Bit
- Appliance Dolly
- Hammer
- Level
- Measuring Tape
- Socket Wrench Set

## **Required materials**

- 4 Floor anchors

Harmar recommends securing the lift using our Anchor Kit. If you purchase you own floor anchors they must use 3/8" bolts and have a minimum tensile strength of 6000 LBS.

## Preparing to Install the Lift

### Final Site Inspection

Verify the surface the lift will mount to is smooth and level. This surface must be made from 3,500 psi reinforced concrete with a minimum thickness of 4".

Verify that there is enough space for the lift's foot print. Be sure to include space necessary for platform.

**Caution: Verify that the running clearance around the lift complies with any codes for your area.**

- The horizontal gap between the edge of the platform and the upper landing must be no less than 3/8" and no greater than 3/4".
- The horizontal gap between the guard panel and any wall or barrier must be no less than 2" and no greater than 3".
- Verify that sufficient head room exists above the lift. The lift will require 6' 8" of clearance above the platform floor when the lift is at the upper landing.

**Warning: The area between the floor where the lift is mounted and the top landing must be covered by a smooth vertical fascia. This is to eliminate any pinch points between the platform and landing.**

### Connecting to Electricity

The lift will require a 115 VAC 20 amp grounded electrical circuit.

Depending on local codes, this connection may need to be routed in electrical conduit and hard-wired.

**Warning: Do not ride on the lift until it has been anchored in place.**

## Controller Harness Connections

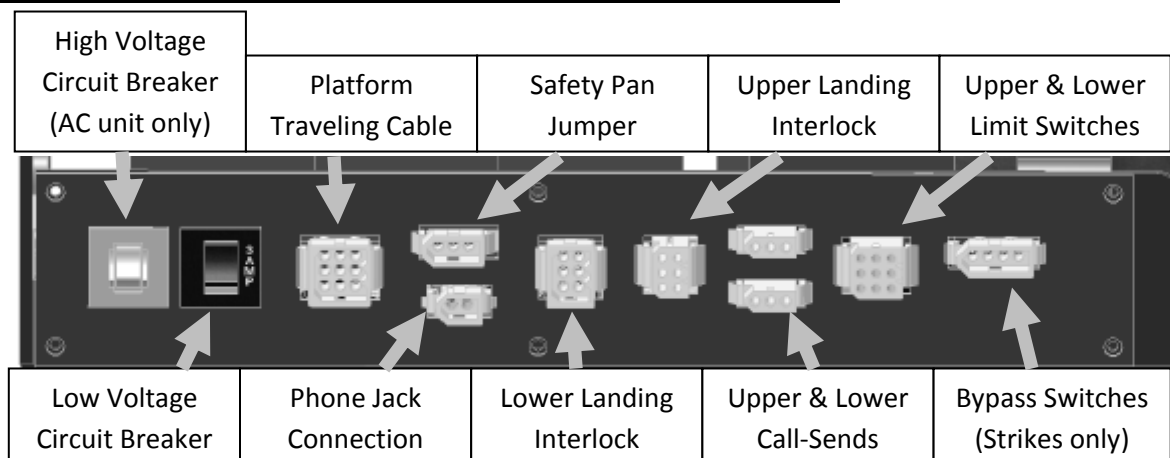

## Installing the Platform

### Step 1

The mounting bolts, nuts and spacers that secure the platform to the lift carriage are packaged in the small parts box. Begin by locating these pieces and setting aside.



### Step 2

Position the platform by aligning the support legs with the carriage flanges that protrude from the front cover.

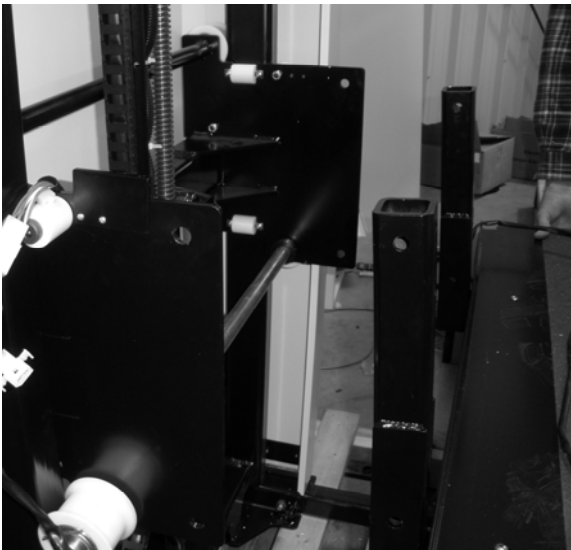

### Step 3

Align the four mounting holes with those on the carriage. Insert 1/2 x 3" hex head bolts into each of the (4) holes. Install the low profile nuts on the upper bolts and the standard ones on the lower bolts.

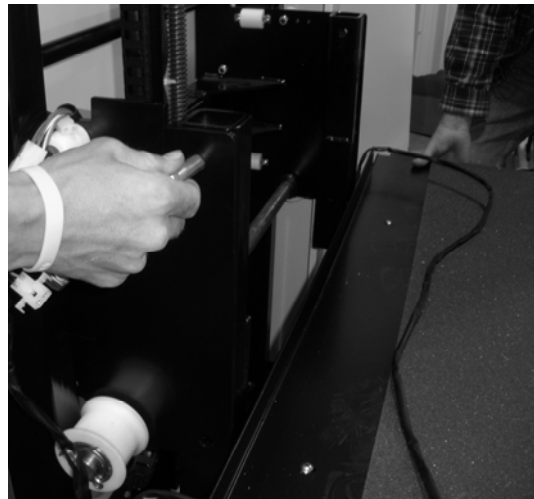

### Step 4

Plug in the harness for the platform safety pan and unplug the safety pan jumper on the controller (ref pg 5). Secure the harnesses under the clip on top of the carriage flange.



## Installing the Platform Guard Panels

### Step 1

Insert the guard panel posts in the pockets in the platform. The smooth side of the guard panel faces toward the center of the platform. Bolt each post in place with (2) 5/16-18 x 2" and (1) 1/4-20 x 2" hex head bolts.

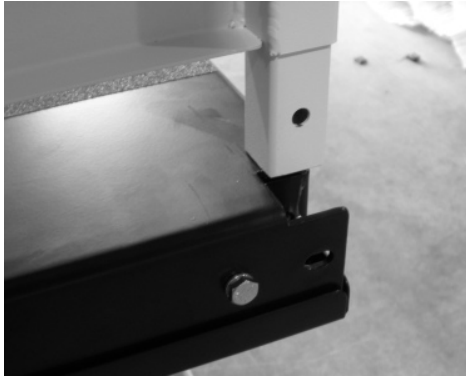

If you have a 90 degree exit platform, install the end guard panel using the provided bracket and bolt to inner guard panel.

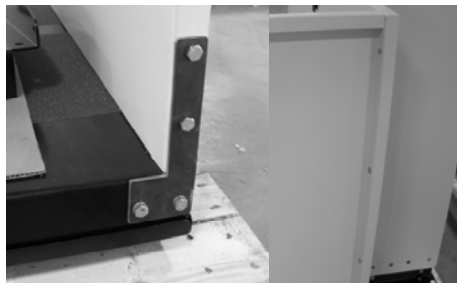

### Step 2

Install the platform control box on the rear guard panel using screws and nuts through the panel.



### Step 3

Plug in the harness for the platform control box. Secure the harnesses under the clip on top of the carriage flange.



## Installing Fixed Ramp

### Step 1

- Position the ramp after the lift is in its final location.
- Maintain a gap of 3/8" to 3/4" between the ramp and platform.
- Drill a pilot hole into the concrete and fasten using supplied concrete lags through ramp flanges.

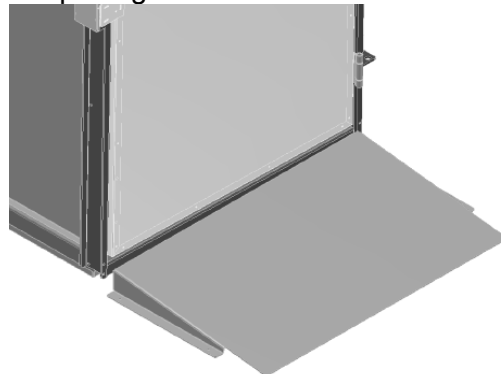

## Installing Auto-folding Ramp (optional)

### Step 1

Install the ramp roller guide on the side of the lift tower using the screws already installed in the panels.



### Step 2

Attach the two ramp pivot tabs to the lower landing sides of the platform. Reinsert the hex bolts, one of which will go through the guard panel post, and tighten.



### Step 3

Attach the ramp to the pivot tabs using shoulder bolts and locking nuts. Tighten the nuts until they seat against the bolt shoulder.

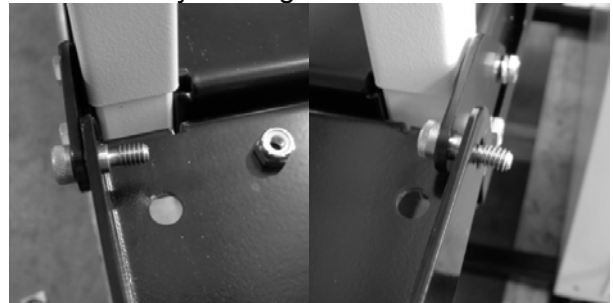

### Step 4

Attach the ramp roller arm by bolting it to the underside of the ramp.



The ramp roller should align and make contact with the ramp roller guide.





## Anchoring the Lift

### Anchors

Harmar recommends securing the lift using the concrete anchors provided. If you purchase your own floor anchors they must be 3/8" minimum of sufficient length. **All four floor anchors must be installed correctly in accordance to their instructions.**

### Step 1

- Position the lift in its final location.
- Verify that it is level and perpendicular to its surroundings and all running clearances are the proper dimension.
- Shim if necessary.

### Step 2

Use the lift's base as a template. Drill 4 holes into the concrete making sure that the holes are deep enough to accept the anchors.

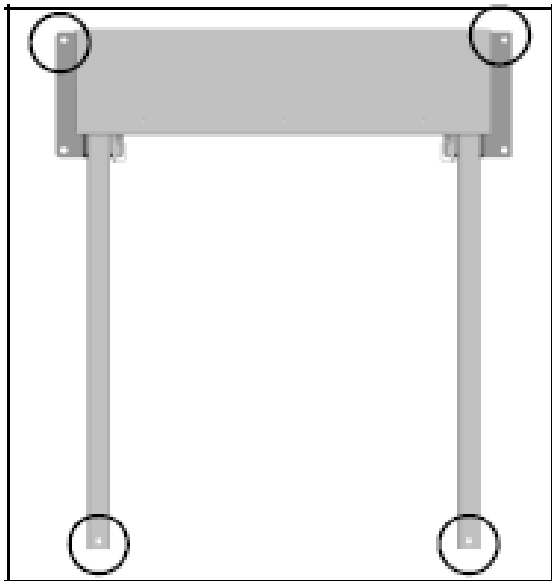

**Tip: Concrete dust may have settled into the holes you just drilled. Use a shop vacuum to clean out these holes. This will ensure the floor anchors set correctly.**

### Step 3

Secure the lift in place by tightening the floor anchor bolts.

### Step 4 (800 or taller models)

Taller lifts must have the top of the lift tower anchored into a solid surface to ensure running clearances remain constant.

There are two options for anchoring the top of the tower:

- 1) For lifts going up to a landing such as a deck or porch, the optional tower brace is the preferred method. Instructions for the brace are packaged with it.

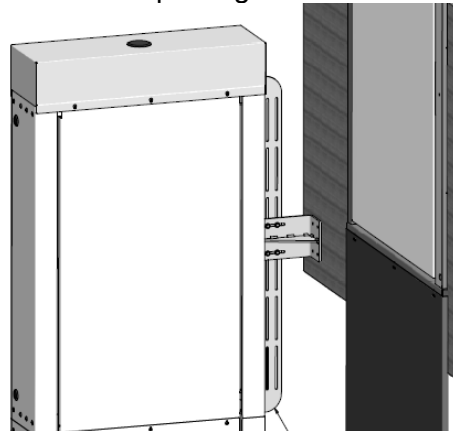

- 2) For lifts that are placed with the back of the tower against a solid wall such as inside of a hoistway, drilling two holes through the top tower cross brace and anchoring is preferred.

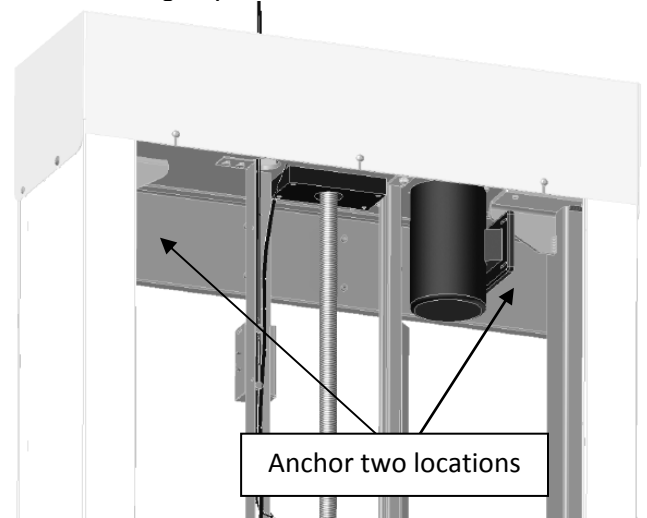

## Setting the Limit Switches

Your lift is equipped with upper and lower limit switches. The vertical location of these switches may be adjusted to fit your application. Typically the upper limit switch will need to be adjusted so the platform will stop level with the upper landing. The lower limit will typically not need adjusting.

### Step 1

Verify the emergency switch is in the ON position. Run the lift in the up direction until the platform floor is level with the upper landing. Disconnect the lift's power (at the building's circuit breaker for AC units, at the battery box for DC units) before going to the next step.

**Warning: Moving components can cut and crush. Do not operate the lift if you are in close proximity to any drive components. Be aware that loose clothing or jewelry may catch on moving parts.**

### Step 2

Remove the screws at the top of the lift that attach the front cover.



### Step 3

Remove the front cover by tilting it forward and lifting upwards. The bottom of the front cover sits on a pin on either side of the lift frame. Set the cover aside in a safe location where it will not get damaged.



### Step 4

Loosen the bolts that attach the upper limit switch assembly. Slide the assembly down the track until the lower switch in the assembly comes in contact with the lift's car. You should hear the limit switch click as contact is made. Retighten the set screw fastening the limit switch assembly in place.



### Step 5

Replace the front cover and secure it with the screws you removed in step 1.

### Step 6

Re-connect the lift's electrical power at the circuit breaker. Verify that the emergency switch is in the on position.

### Step 7

Run the lift in the down direction for several inches. Next, run the lift in the up direction. Continue to press the up button until the upper limit switch has caused the lift to stop. Verify that the platform has stopped level with the upper landing. If it has not, readjust the limit until it is level.

## Verifying Operation of the Lift

**Caution:** Complete the following section before training the customer to use the lift.

### Step 1

Run the lift up and down for 5 complete cycles. Hold the direction button down and allow the limit switches to stop the lift. At the top, verify that the platform stops level with the upper landing. At the bottom, verify the access ramp (if equipped) unfolds and rests on the ground.

### Step 2

Verify the operation of the Emergency stop switch. When this switch is pushed in the lift should not run in either direction. When this switch is turned and pulled back out, the lift should operate normally.



### Step 3

Verify the operation of the sensor pan underneath the platform. Start with the lift at the top landing. Press up on the sensor pan. While holding the pan in this location, press the down switch on the platform. The lift should not run.

**Warning:** Do not run the lift if anyone is under the platform.

## Manual Override

Your lift is equipped with a manual handcrank, to be used in the case of a power failure.

### **Step 1**

Before using the manual handcrank verify that it's use is required. Check that the emergency stop switch is pulled out. Check that the electrical cord is connected to the supply. Also check that the buildings circuit breaker has not tripped. Try to run the lift by pushing both the up and down buttons. If the lift still will not run, complete the following steps:

### **Step 2**

Disconnect the power from the lift.

**Warning: Do not service or operate the manual handcrank while the lift is connected to electricity.**

### **Step 3**

Remove the screws and remove the top cap at the top of the tower.



### **Step 4**

Insert the manual handcrank into the opening on the top of the brake assembly. It may be necessary to slightly rotate the handcrank until it fully seats down on the hex portion of the brake. Rotate the crank to raise or lower the platform.

**Warning: Never operate the lift while the manual override crank is inserted into the lift.**

## Call-Sends (optional)

The optional Call-Send controls are to be used at the upper and/or lower landings to call the platform to you or send it to the other landing.

They should be mounted on the wall at each landing at a convenient height. Consult local codes for placement with consideration to clearances.

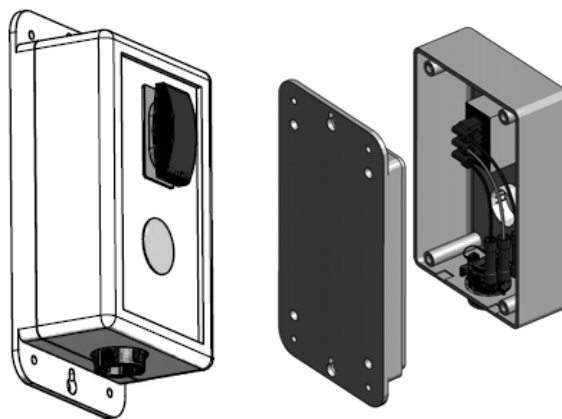

A length of multi-conductor wire will need to be ran from the bottom of the lift tower up to the landing Call-Sends. Consult local codes for type and mounting requirements. After wiring is completed, the wiring harness must be plugged into it appropriate receptacle on the controller (ref pg 5).

### Wiring Connections

<u>Call-Send</u>	<u>Lift Harness</u>
Blue	Blue
White	White
Red	Red

## Top Landing Gate (optional)

The optional top landing gate is provided with a combination mechanical lock and electric contact (interlock).

The interlock:

- Prevents the lift from running if the gate is not closed.
- Prevents the gate from being opened if the platform is not at the top landing.
- Unlocks when the lift is on the upper limit switch.

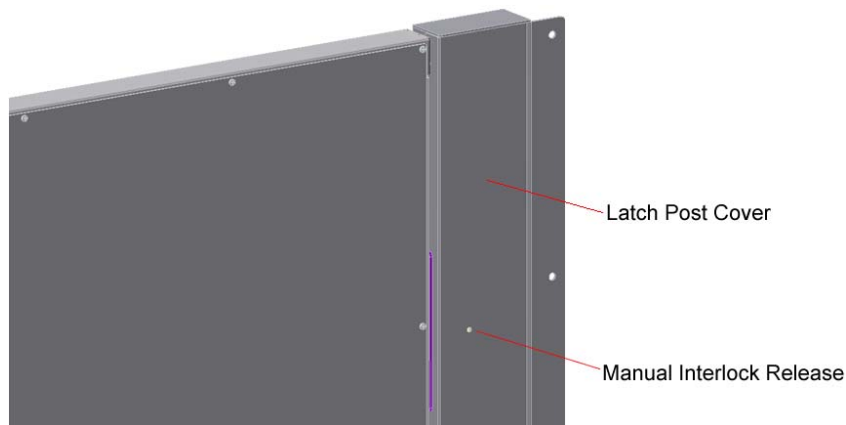

A crescent shaped key is provided to manually unlock the gate during installation. The key is inserted from the back side to lift up on the solenoid that holds the gated locked.

Mount the gate by placing onto the upper landing making sure to align the gate opening with the platform (outer guard rail not shown for clarity).

There are a number of attachment holes provided in the threshold portion of the gate for mounting using wood lag screws or concrete anchors as appropriate.

Remove the latch post cover and connect the call-send and interlock wire harnesses.

The vertical posts of the gate must be attached to a supporting structure, (the gate is not designed to be freestanding).

A length of multi-conductor wire will need to be ran from the bottom of the lift tower up to the landing gate. Consult local codes for type and mounting requirements. After wiring is completed, the wiring harness must be plugged into it appropriate receptacle on the controller (ref pg 5).

### Wiring Connections

<u>Interlock Harness</u>	<u>Lift Harness</u>
Black	Black
Black	Green
Yellow	White
Yellow	Orange
	*Blue
	* Brown
*Must be tied together	

<u>Call-Send Harness</u>	<u>Lift Harness</u>
Blue	Blue
Yellow	White
Red	Red



## EMI and Flush Strike Interlocks (optional)

The optional EMI or Flush Strike Interlocks are provided with a combination mechanical lock and electric contact. They are to be used with existing doors.

The interlock:

- Prevents the lift from running if the door is not closed.
- Prevents the door from being opened if the platform is not at the landing.

A length of multi-conductor wire will need to be ran from the bottom of the lift tower to each interlock. Consult local codes for type and mounting requirements. After wiring is completed, the wiring harness must be plugged into it appropriate receptacle on the controller (ref pg 5).

### Flush Strike Interlock

Refer to the instructions inside the strike box for mounting requirements.

### EMI Interlock



- 1) Position interlock to door jamb and mark mounting holes.
- 2) Fasten Interlock to door jamb with #8 wood screws.
- 3) Route 4-conductor Interlock cable thru hole in top of interlock and make wire connections.
- 4) Attach door keeper and emergency key plates to hoistway door.

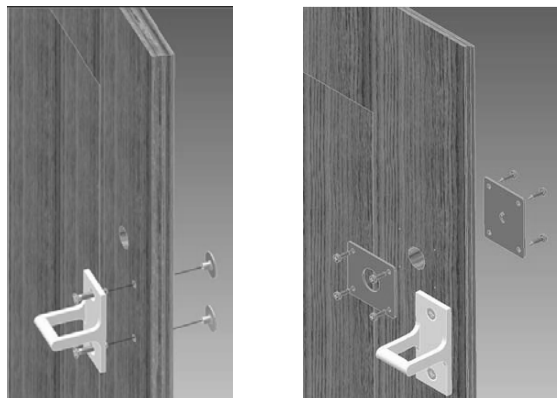

#### Flush Strike Interlock Wiring Connections

##### For AC powered lifts

Flush Strike Wires	Rectifier Wires	Lift Harness Wires
Black-White Stripe	Red	
Black-White Stripe	Black	
	Yellow	Black
Yellow	Yellow	Green*
Blue		White
Grey		Orange
Green	Red	Blue
Red	Black	Brown
Black	Yellow	Red
	Yellow	Green*

##### For Optional DC powered lifts

Flush Strike Wires	Lift Harness Wires
Black-White Stripe	Black
Black-White Stripe	Green*
Yellow	White
Blue	Orange
Grey	Blue
Green	Brown
Red	Red
Black	Green*

\* This is a single wire that will have 2 wires connected to it.

#### EMI Interlock Wiring Connections

EMI	Lift Harness
Black (A)	Black
Black (B)	Green
Yellow (C)	White
Yellow (D)	Orange
N/A	Blue+
N/A	Brown+
N/A	Red

+Must be tied together when using an EMI Interlock.

## **Platform Gate (optional)**

The optional platform gate is provided with a combination mechanical lock and electric contact (interlock).

The interlock:

- Prevents the lift from running if the gate is not closed.
- Prevents the gate from being opened if the platform is not at the bottom landing.
- Unlocks when the lift is on the lower limit switch.

A crescent shaped key is provided to manually unlock the gate during installation. The key is inserted from the back side to lift up on the solenoid that holds the gated locked.

Mount the gate by placing onto the lower landing side of the platform. There are a number of attachment holes along the bottom and up the sides of the gate frame to attach to the platform and guard panels.

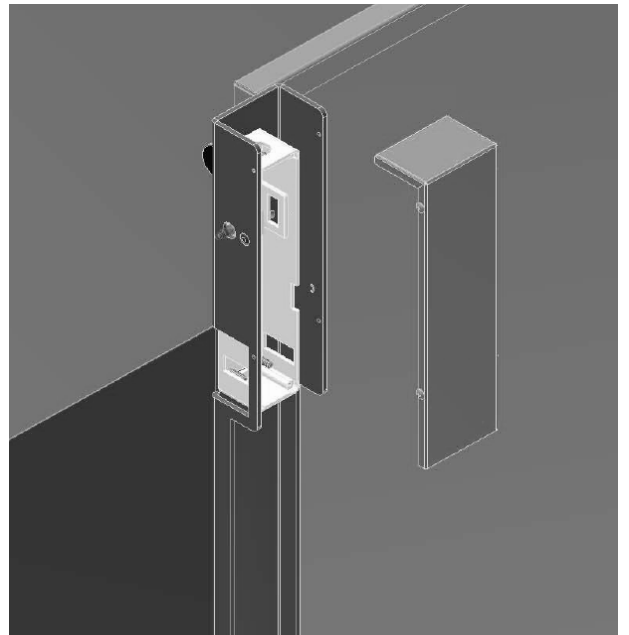
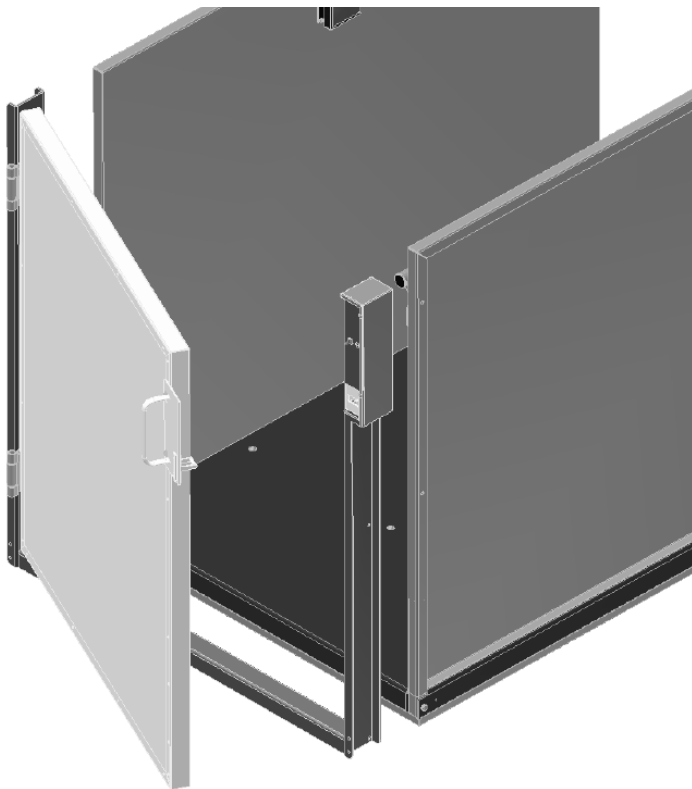

A wiring harness included on the gate will need to be routed along the gate frame, behind the rear guard panel and connected to its adjoining harness plug on the lift carriage. After wiring connection is made, the wiring harness must be plugged into its appropriate receptacle on the controller (ref pg 5).

## **Fascia Panel (optional)**

A fascia panel provides a smooth surface for the platform edge to run against to prevent any shear or obstruction hazards and must be utilized.

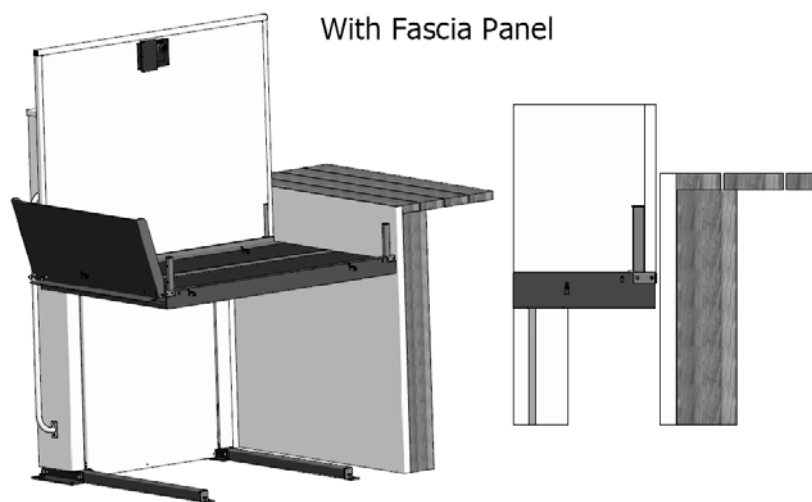
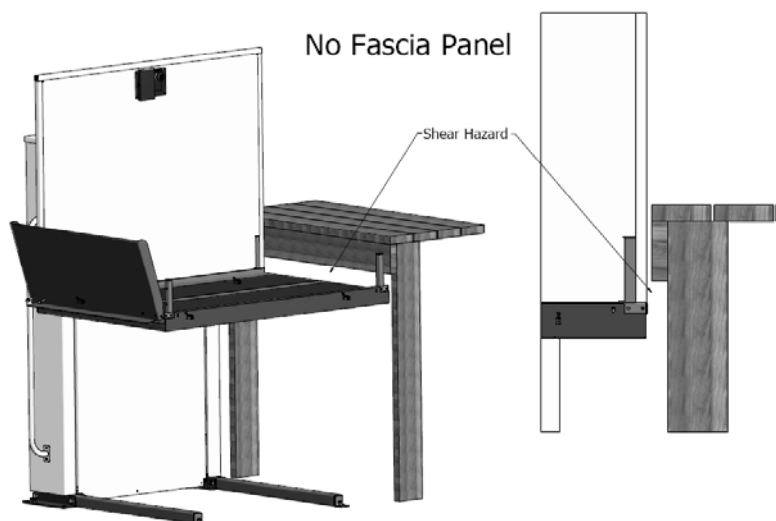

A running clearance of no more than 3/4" and no less than 3/8" must be maintained between the edge of the platform and the fascia panel.



## Platform Control with Optional E-Stop Alarm

If equipped, the e-stop button on the platform lights up and sounds an alarm when pressed.

You will need to obtain a 6 volt lantern battery like the example below.



The battery can sit under the top cap to the right of the motor pulley. There is a wire harness for the battery located here. Wire #1 connects to the positive terminal and wire #2 to the negative terminal.

## Commercial Platform Lift - Owners Section



**ⓘ Read the manual thoroughly before operating the lift.**

Congratulations on the purchase of your Harmar Vertical Platform Lift. This lift has been engineered to provide trouble free service for many, many years. Please read this manual completely before operating your lift.

## **Safety**

- Do not exceed the maximum payload capacity of 750 lbs.
- Do not ride on the lift until it is anchored in place.
- This product is designed only for lifting people and wheel chairs. Do not use it for any other purpose.
- Make sure any obstructions are cleared from underneath the platform area before use.
- Make sure both the passenger and wheelchair are completely on to the platform before using.
- Do not disable any safety equipment or switches supplied with this lift.
- Do not attempt to service the lift yourself. Contact your Harmar dealer for assistance.
- Do not allow children to operate or play around the lift.
- Read all instructions in this manual before installing or operation the lift.

## Controls



### **Emergency Stop**

In an emergency push this red button to stop the lift. Turn the button clockwise to run.

### **Up**

Controls upward movement of lift platform. To move platform up, depress and hold the upper half of the rocker switch. To cease movement, release switch.

### **Down**

Controls downward movement of lift platform. To move platform down, depress and hold the lower half of the rocker switch. To cease movement, release switch.

### **Keylock (optional)**

Disables controls from operating when keylock is turned off.

## Operating the Lift

### Step 1 - Up

Drive onto and stop in the middle of the platform. Apply the brakes of your chair or scooter.



### Step 2

Verify that the emergency stop button is not activated by giving it a quick turn clockwise.

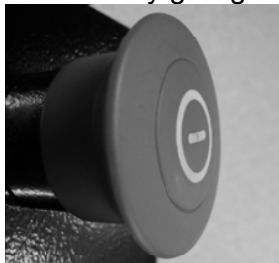

### Step 3

Press and hold the UP rocker. The lift will move in the up direction and stop when it reaches the upper landing.



**Warning:** Always verify the lift's platform has stopped level with the upper landing. If not contact your Harmar Dealer for assistance.

### Step 4

Release the brakes on your chair or scooter and drive off the platform.



**Step 1 - Down**

Drive onto and stop in the middle of the platform. Apply the brakes of your chair or scooter.

**Step 2**

Verify that the emergency stop button is not activated by giving it a quick turn clockwise.

**Step 3**

Press and hold the DOWN rocker. The lift will move in the down direction and stop when it reaches the lower landing.



**Warning:** Always verify the lift's access ramp unfolds fully and rests on the ground. If not contact your Harmar Dealer for assistance.

**Step 4**

Release the brakes on your chair or scooter and drive off the platform.



1 2 3 4

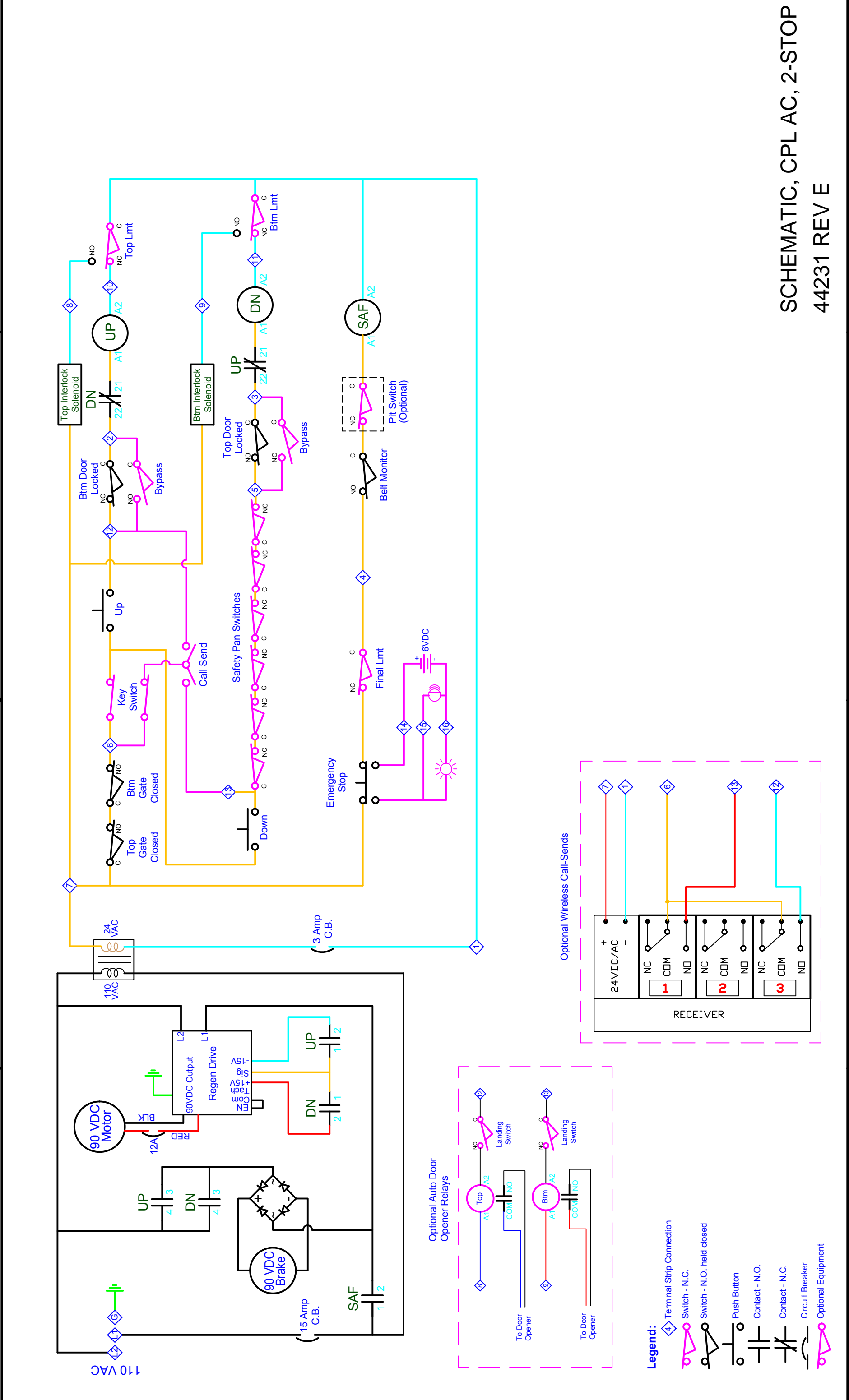

**SCHEMATIC, CPL AC, 2-STOP**  
**44231 REV E**

- Legend:**
- 4 Terminal Strip Connection
  - Switch - N.C.
  - Switch - N.O. held closed
  - Push Button
  - Contact - N.O.
  - Contact - N.C.
  - Circuit Breaker
  - Optional Equipment

1 2 3 4

1 2 3 4

B

A

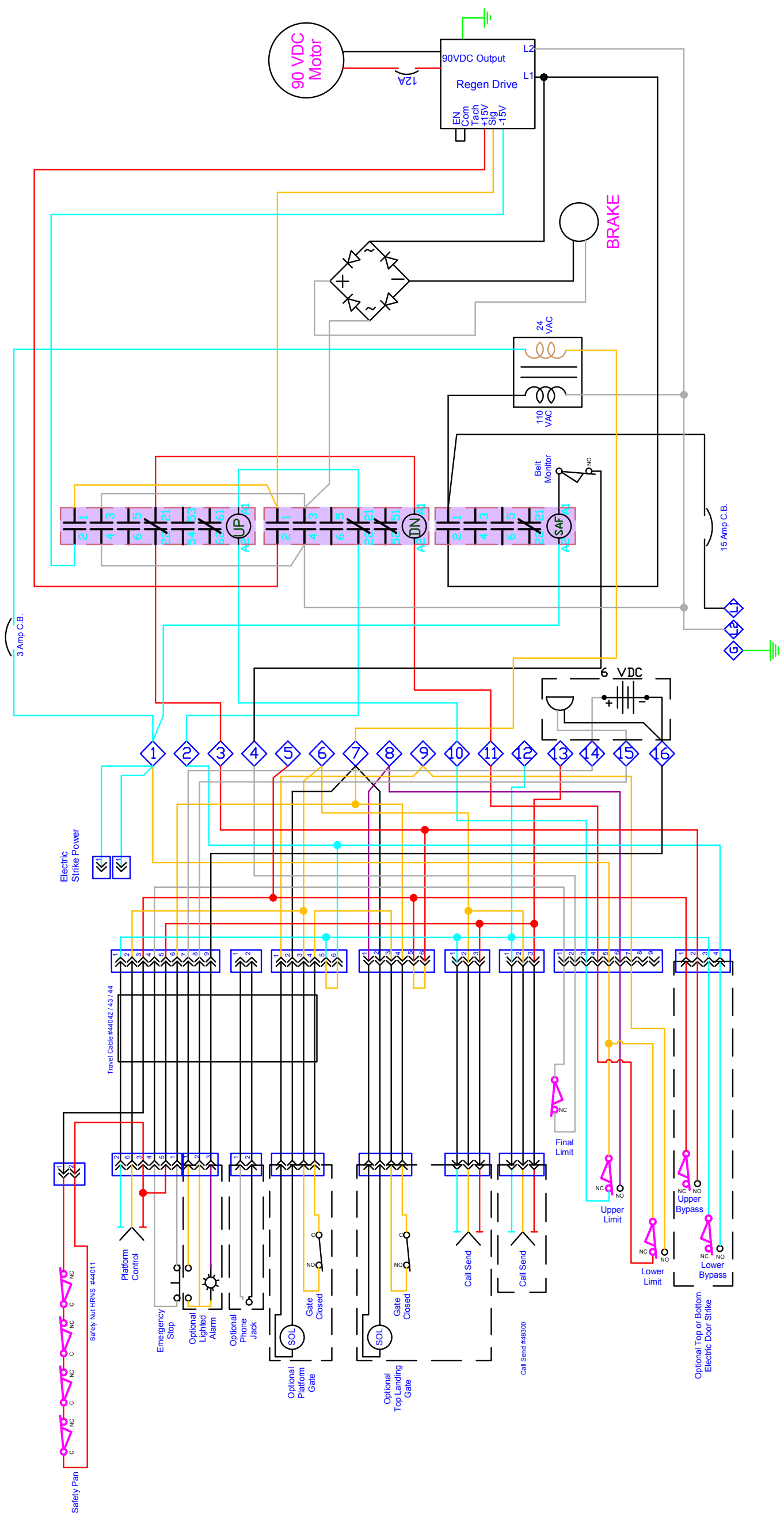

**WIRING DIAGRAM, CPL AC, 2-STOP**  
**44231 REV D**

1 2 3 4

B

A

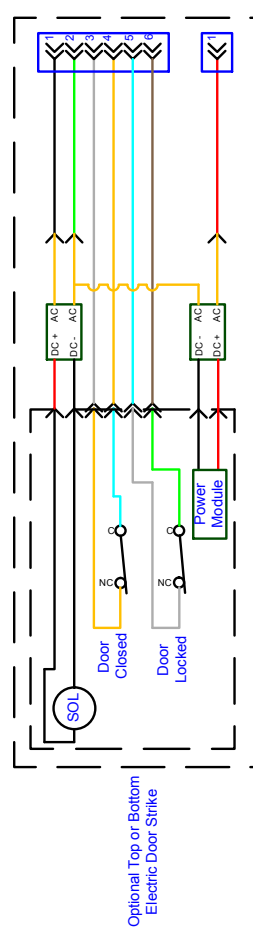



1 2 3 4

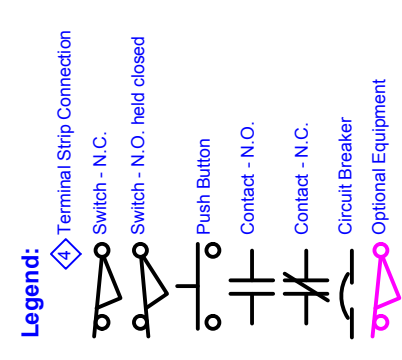
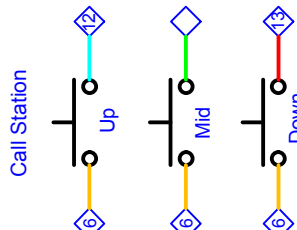
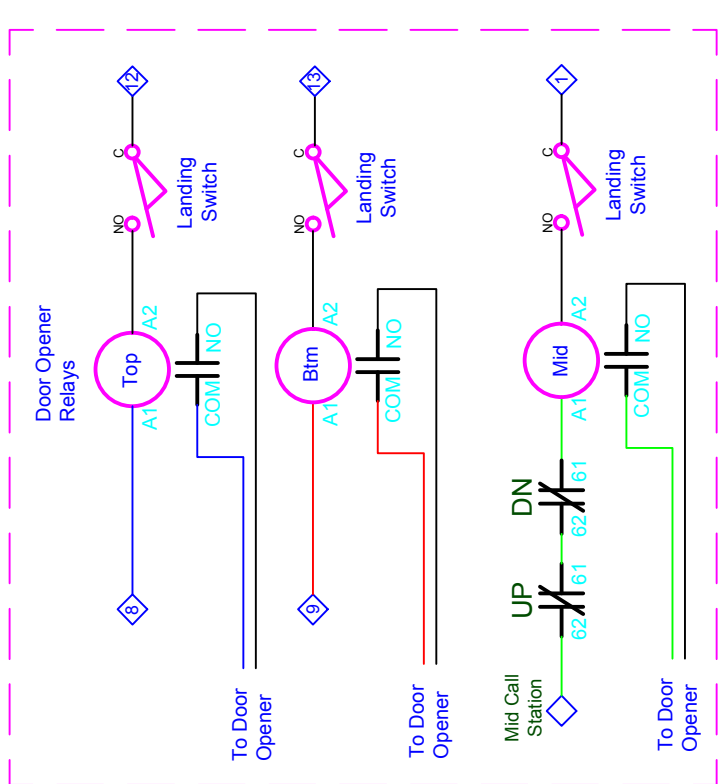
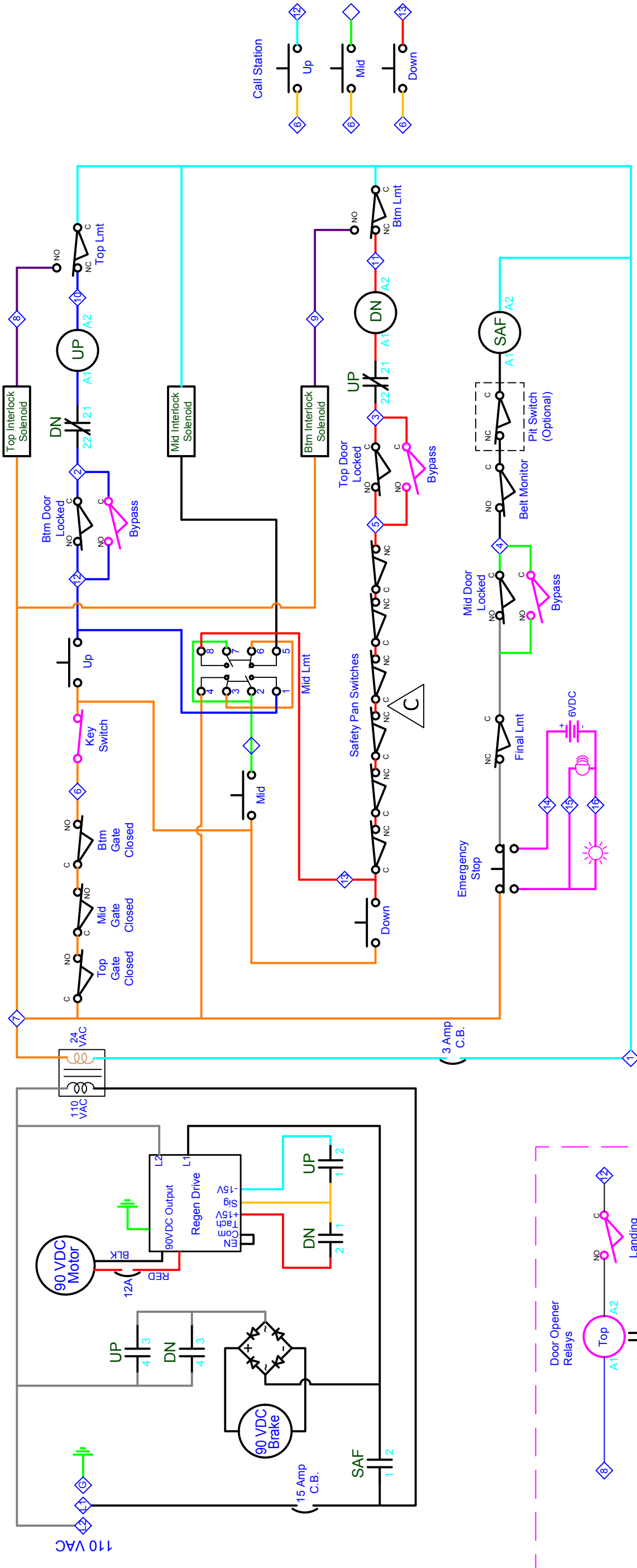

SCHEMATIC, CPL AC, 3-STOP  
44331 REV C

1 2 3 4

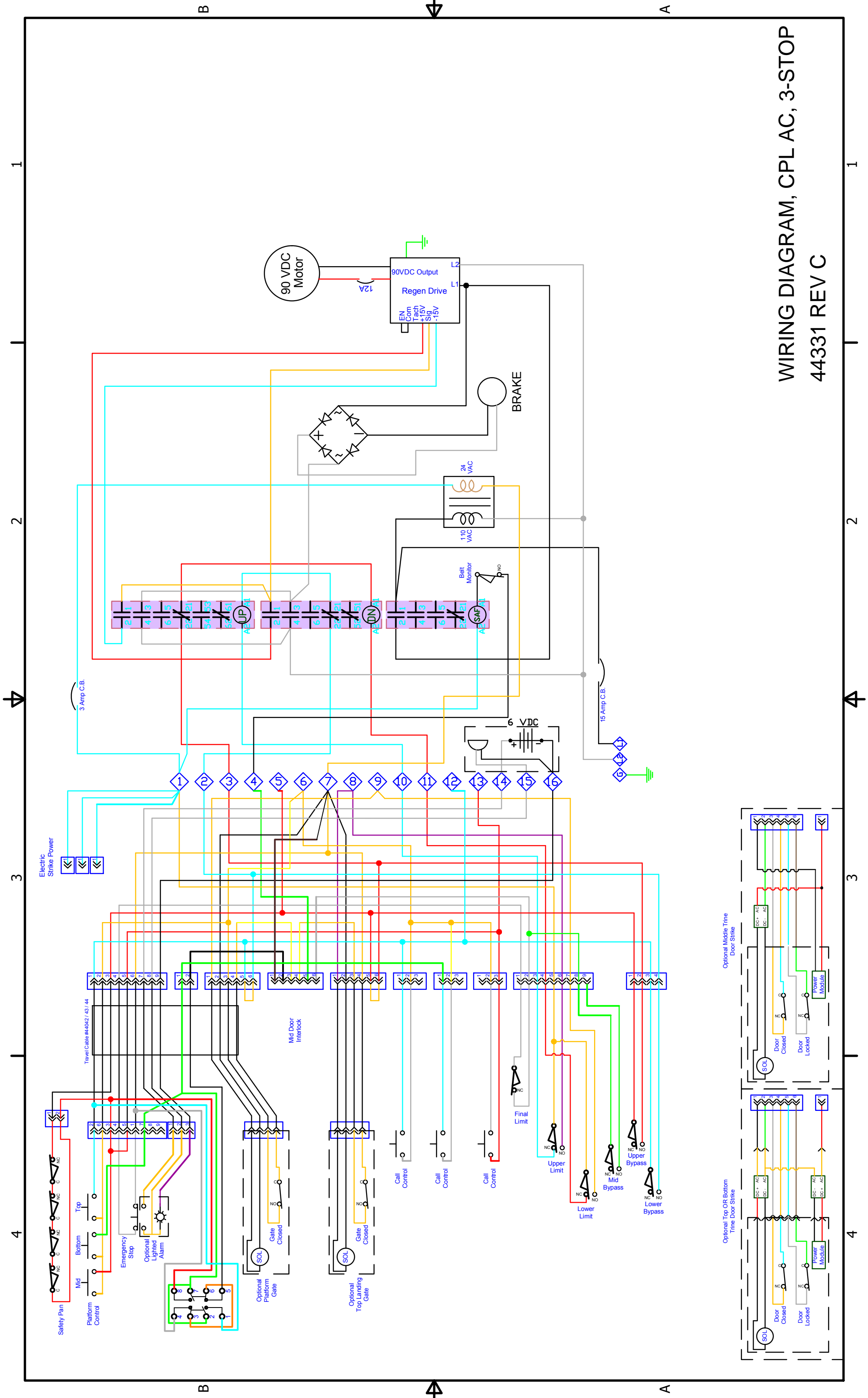

**WIRING DIAGRAM, CPL AC, 3-STOP  
44331 REV C**

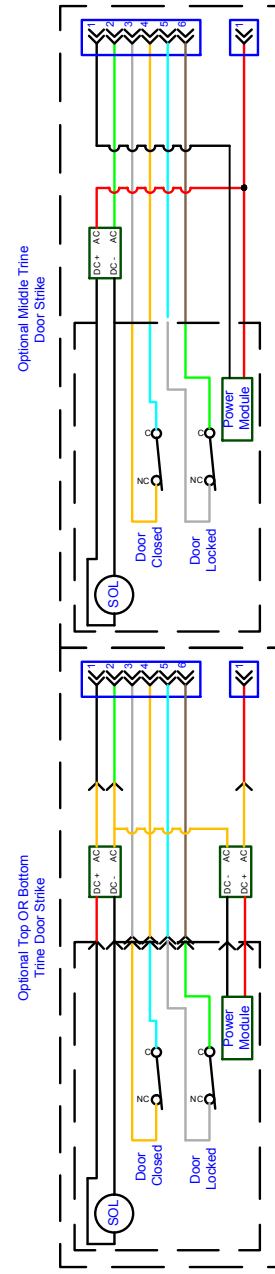

1 2 3 4

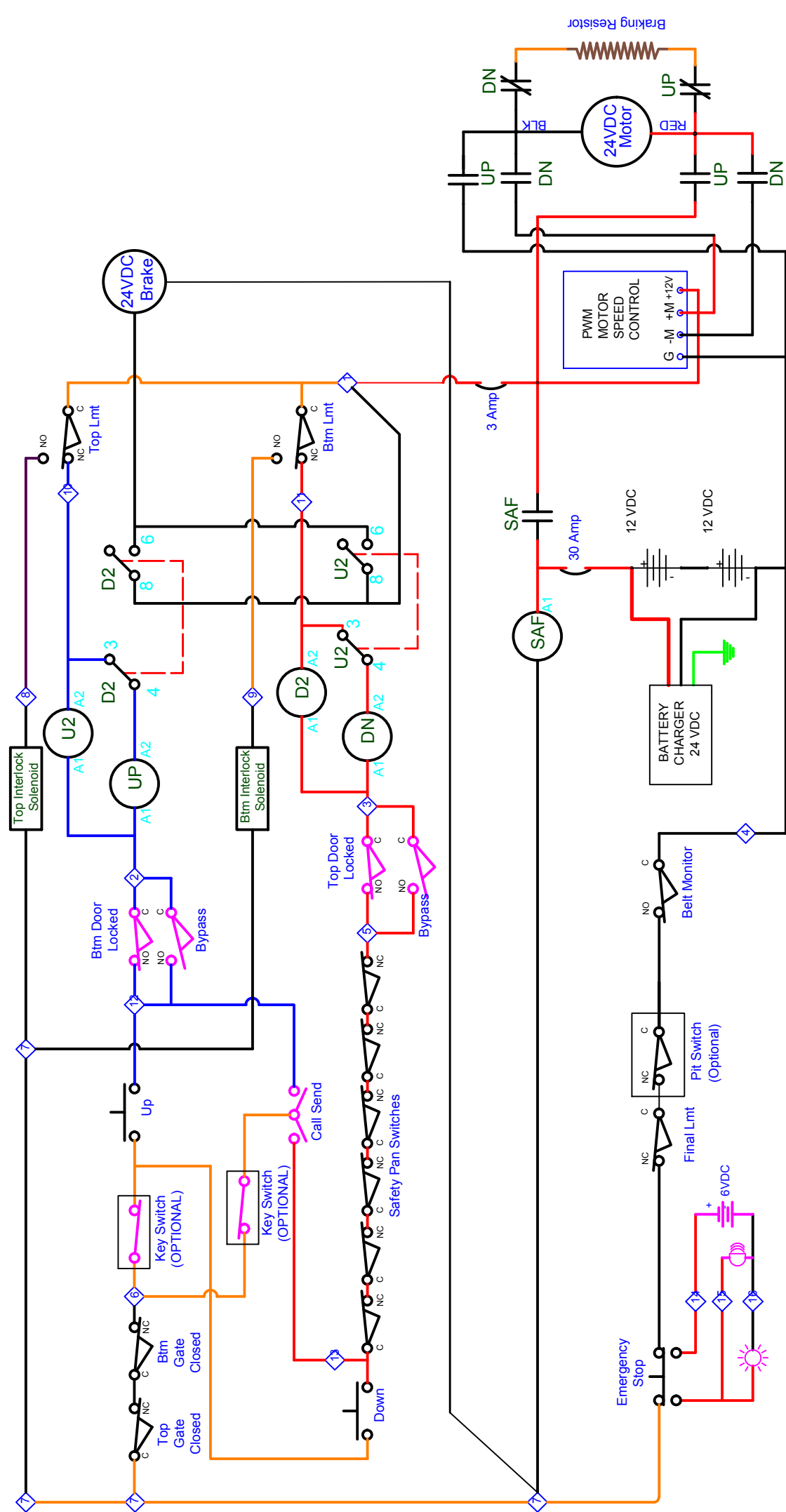

- Legend:**
- Terminal Strip Connection
  - Switch - N.C.
  - Switch - N.O. held closed
  - Push Button
  - Contact - N.O.
  - Contact - N.C.
  - Circuit Breaker
  - Optional Equipment

SCHEMATIC, CPL DC, 2-STOP  
44141 REV F

1 2 3 4

1 2 3 4

B

A

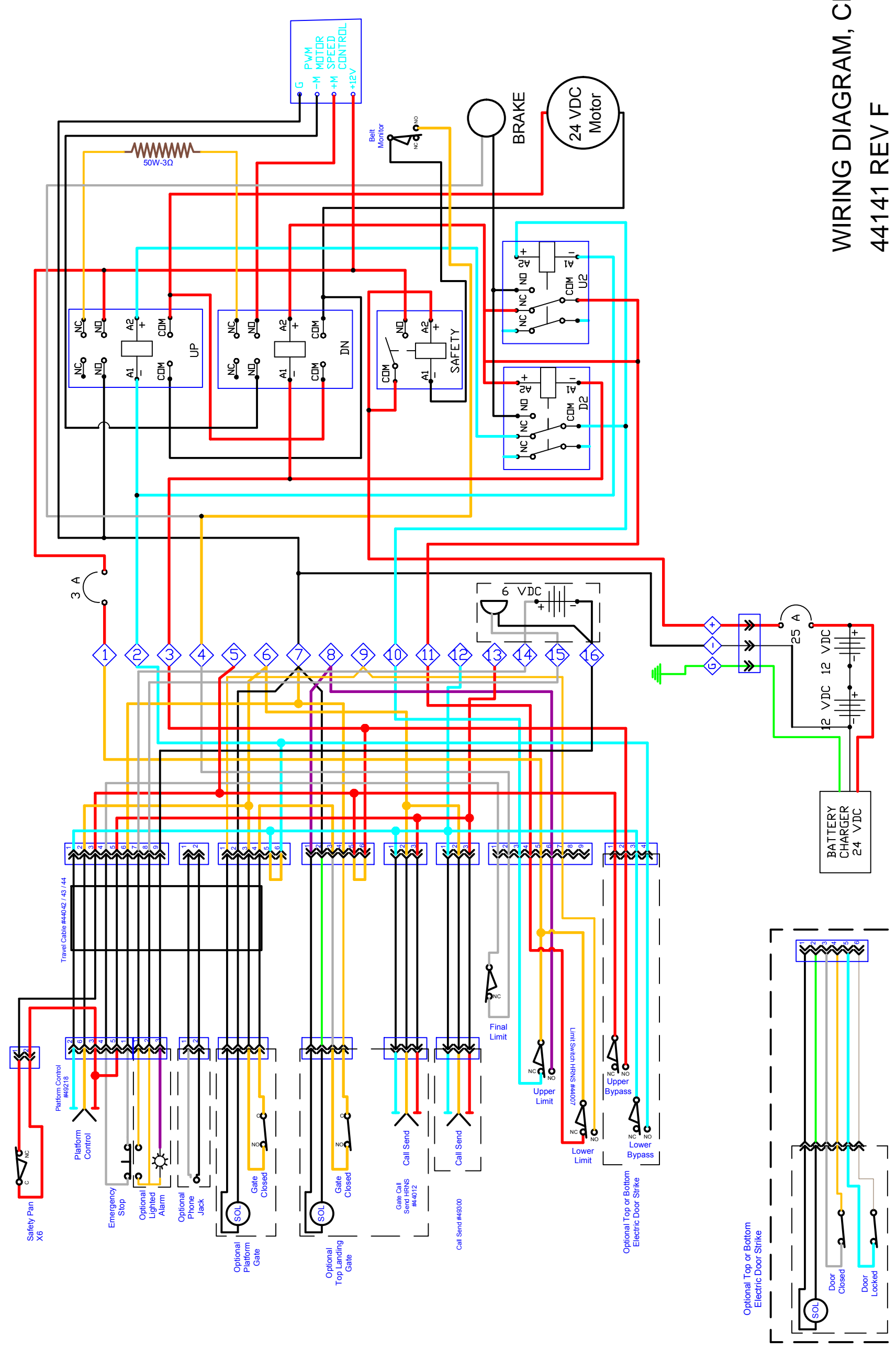

WIRING DIAGRAM, CPL DC, 2-STOP  
44141 REV F

B

A

1 2 3 4

1 2 3 4

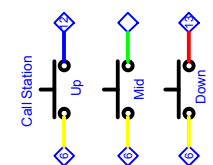
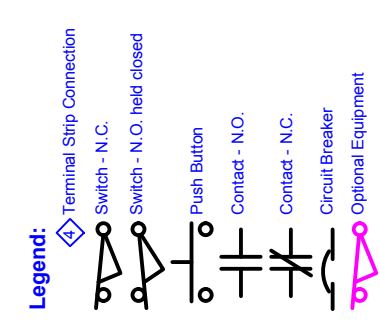
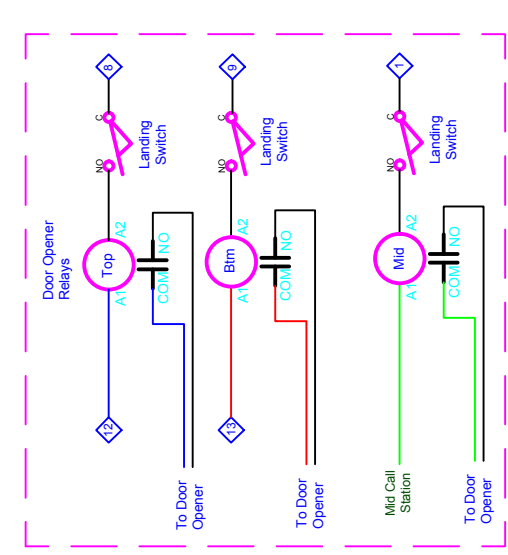
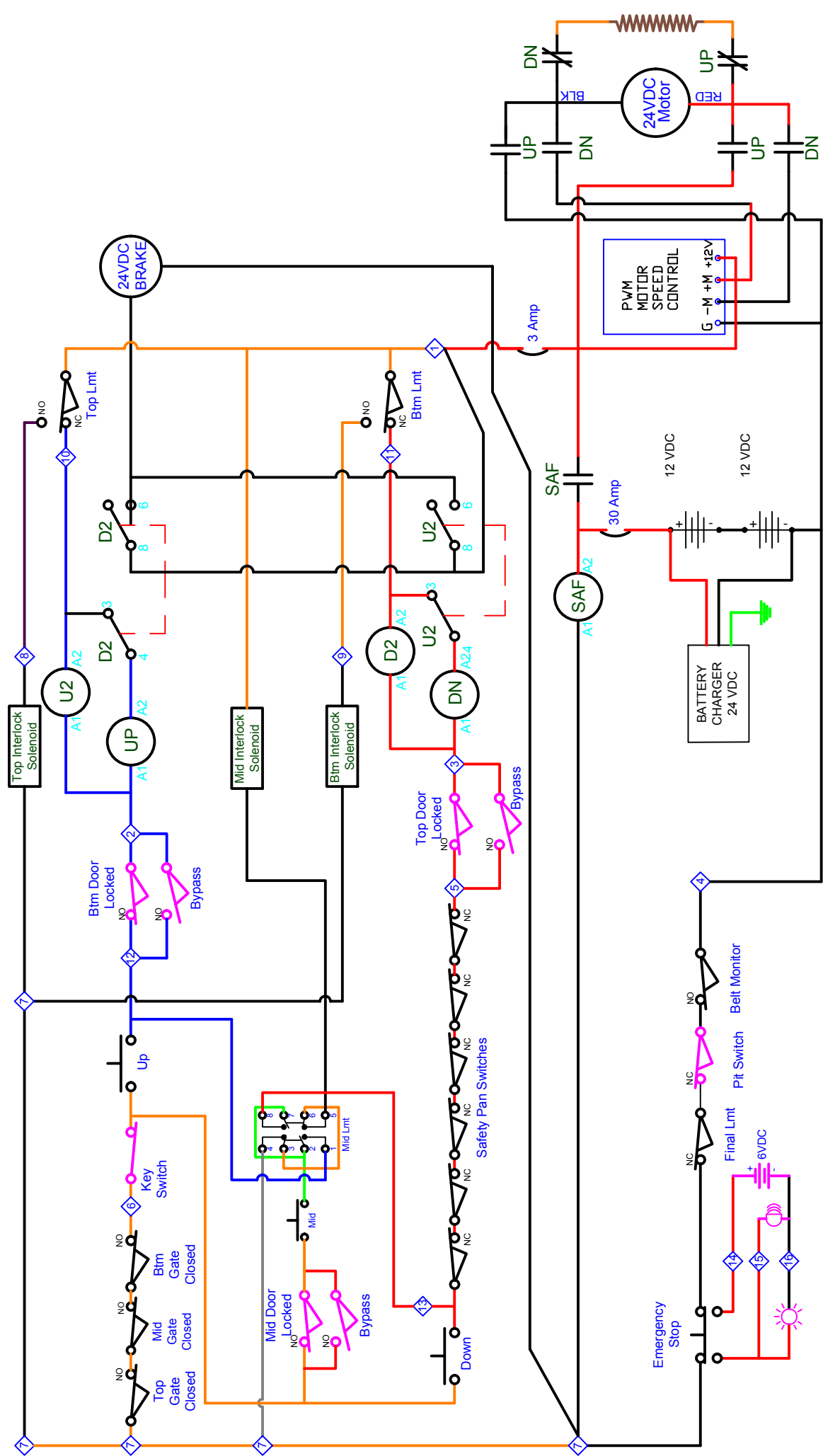

WIRING SCHEMATIC, CPL DC, 3-STOP  
640-00005 REV A

1 2 3 4



## HIGHLANDER CPL- TWO YEAR WARRANTY CERTIFICATE

### LIMITED WARRANTY CERTIFICATE

Products Covered: CPL400 – 1400; EPL400 – 1400; TG400; CPL400P

Harmar warrants to the original purchaser of a Highlander Commercial Vertical Platform Lift (CPL) manufactured by us to be free from defects in material, mechanical and electrical components (parts) for a period of two (2) years, provided that the products have been installed, maintained and operated properly by an Authorized Harmar Distributor or certified Harmar Installer.

#### EXCEPTIONS TO THIS LIMITED WARRANTY ARE: PLEASE READ CAREFULLY

- Harmar CPL's and EPL's installed outdoors must include the Premium Protection Package to maintain 2-year warranty; otherwise warranty is limited to one (1) year.
- Batteries are limited to one (1) year with a Harmar supplied/approved charger.
- Damage resulting from improper installation or operation
- Additional parts/labor related to code compliance that were not identified on the original order
- Negligence, alterations, abuse or misuse of the equipment
- Fire, flood, acts of God
- Shipping damage
- Parts used that are not approved by Harmar Mobility, LLC.
- Labor fees for installation work, repair or service calls are not covered
- Outdoor installation **within 1 mile of a coastline** reduces warranty to 180 days and expressly excludes rust after 30 days. Warranty is extended to 2 years with Premium Protection Package Option.
- Due to the nature of steel construction being permanently placed in an outdoor environment and its inherent unpredictability, **minor paint defects and cosmetic rust are not covered after 30 days** by Harmar's Limited Warranty.
- Harmar enclosures, when used, are designed to protect a CPL and its users from being directly affected by the elements. **It is NOT intended nor designed to be completely water proof.**

**This warranty starts on the date of initial product installation (not to exceed 90 days from the date of manufacture), provided the warranty certificate is completely filled out and returned to Harmar within ten (10) days of installation.** Harmar and its dealers shall not be liable for any consequential, special or incidental damages arising out of the purchase or use of the unit or resulting from the breach of this Limited Warranty, or any implied warranty. The limit of liability of Harmar and its dealer hereunder shall be the unit's purchase price. Some states do not allow limitations on how long an implied warranty lasts or the exclusion or limitation of incidental or consequential damages, or legal remedies, so these above limitations may not apply to you. All warranty claims must be reported to the dealer from whom the lift was purchased as they have responsibility for handling your warranty claim. The dealer is to contact the Technical Services Department of Harmar and provide the serial number of the product along with a description and evidence of the defect(s) supporting a warranty claim. Dealers may charge for labor, service, travel, or other associated costs to make repairs, and such charges are not covered by this Limited Warranty. It is permissible to have any repairs or replacement work done as a result of any defects in material and workmanship by someone other than the Dealer under this Limited Warranty. However, the Limited Warranty does not cover any charges or expenses assessed by any such other person or company performing such repairs or replacement work. All parts used to replace defective materials must be genuine Harmar parts to be covered by this Limited Warranty. This Limited Warranty gives you specific legal rights, and you may have other rights which vary from state to state. Harmar will not be charged for labor, consequential damage or repair expenses. Harmar will not, under any circumstances, be liable for the loss of the use of its products or loss of time. Defective parts must be returned, if requested, prepaid, to Harmar for inspection prior to credit or replacement. At Harmar's discretion, any part found to have been modified, over-stressed, damaged by accident, or misused is not covered by this warranty. **THIS WARRANTY IS IN LIEU OF ALL OTHER WARRANTIES OR CONDITIONS, INCLUDING ALL IMPLIED WARRANTIES OR MERCHANTABILITY OR FITNESS FOR A PARTICULAR PURPOSE, AND THERE ARE NO WARRANTIES THAT EXTEND BEYOND THE DESCRIPTION OF THE LIMITED WARRANTY DESCRIBED HEREIN.**



**Highlander Commercial Platform Lift**  
Installation and Owner's Manual

